

LM100/LM200

High Precision Class 2 Laser Measurement

SERIES



LM100



LM200

* Original NAIS Sensor

● Inspection speed selectable for a wide range of applications.

LM100 Series

Part No.	Measurable range (mm)					Resolution (μm)	Response time
	30	40	75	130	180		
ANL1451REC						7.5 25 75	10Hz 100kHz 1kHz
ANL1751REC						30 100 300	10Hz 100Hz 1kHz
ANL1651REC						60 200 600	10Hz 100Hz 1kHz

LM200 Series

Part No.	Measurable range (mm)					Resolution (μm)	Response time
	30	40	75	130	180		
ANL2335REC						1.5 5 15	30kHz 300kHz 3kHz
ANL2535REC						4.5 15 45	30kHz 300Hz 3kHz

● High immunity to roughness, reflectivity or color changes (RRC)

Light intensity feed back and triangulation range measurement systems minimize analog output error caused by material or color changes.

● Excellent linearity characteristics with aspherical glass lens

The lens used in the LM laser analog sensor is of a high-precision, aspherical type. This assures accurate detection without spherical and coma aberration, and also reduces temperature drift.

● Excellent environmental resistance;

Equivalent to IEC IP67 (Immersion-protected)

● Sample & Hold function enables the continuous operation even on poor target.

● Safety design incorporated (conforming to CENELEC HD 482 S1).

● Optical triangulation range measurement system

The laser beam emitted from the light emitting element (semiconductor laser) passes through

the projector lens to a target. A part of the diffuse-reflected laser light passes through the receiver lens to a spot on the position sensitive device (PSD).

The position of the light spot varies according to the detection distance. As this variation is measured, the distance to the object can be interpreted. And analog output is then provided.

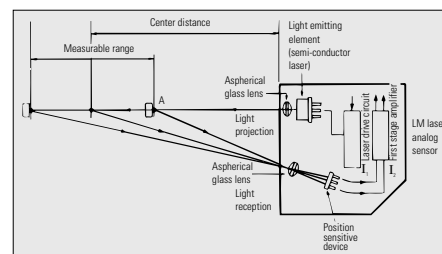

PRODUCT TYPE (Sensor and controller as a set)

1. LM100 Series

Measurable range	Part No.	Rated operating voltage (V DC)	Response time
30mm to 50mm	ANL1451REC	12 to 24	10Hz (40ms), 100Hz (4ms), 1 kHz (0.4ms) switch selectable
50mm to 100mm	ANL1751REC		
80mm to 180mm	ANL1651REC		

2. LM200 Series

Measurable range	Part No.	Rated operating voltage (V AC)	Response time
27mm to 33mm	ANL2335REC	200/220 to 240	30Hz (15ms), 300Hz (1.5ms), 3kHz (0.15ms), switch selectable
44mm to 56mm	ANL2535REC		

ACCESSORIES

	Cable length	Part.No.
Extension cable (Controller to sensor)	2m	ANR81020
	3m	ANR81030
	5m	ANR81050
	10m	ANR81100
	20m	ANR81200

LM100/LM200

SPECIFICATIONS

LM 100 Series

		ANL 1451 REC			ANL 1751 REC			ANL 1651 REC			
Center point distance		40mm			75mm			130mm			
Measurable range		±10mm			±25mm			±50mm			
Light source		Laser diode, wavelength 670nm (pulse duration 12.5µs, 50% duty ratio)									
Laser protection class		Class 2 (Max. output 1.6mW)									
Output voltage		±5V/F.S. (0 to 10V/F.S. SW selectable) Max. 2mA									
Output impedance		50Ω									
Analog displacement output	Resolution (2σ)	White ceramic	7.5µm (10Hz)	25µm (100Hz)	75µm (1kHz)	30µm (10Hz)	100µm (100Hz)	300µm (1kHz)	60µm (10Hz)	200µm (100Hz)	600µm (1kHz)
		Gray ceramic									
	Linearity error	*	Max. ±0.2% of F.S.								
	Material error	**	Max. ±0.5% of F.S.								
	Zero-point adjustment range		10% of F.S.								
	Temperature drift		Sensor section: Max. ±(0.02% of F.S.)/°C			Controller section: Max. ±(0.01% of F.S.)/°C					
	Response frequency (-3dB) Response time (10 to 90%)					1kHz 0.4ms	100Hz 4ms	10Hz 40ms		(SW selectable)	
Alarm output		Transistor output (NPN): 100mA, 30V DC (Open collector)									
Intensity output		0 to 4.5V									
Protective construction (sensor)		IP67									
Vibration resistance (when mounted with screws)		10 to 55Hz (1 cycle/min.), double amplitude			0.75mm (controller section) 1.5mm (sensor section)			2h on 3 axes			
Shock resistance (when mounted with screws)		Min. 20G, 3 times on 3 axes									
Ambient light level		Incandescent lamp: Max. 3,000 lux									
Ambient temperature		0°C to 50°C									
Storage temperature		-20°C to 70°C									
Ambient humidity		35% to 85%RH (without dew condensation)									
Rated operating voltage		12 to 24V DC (10.2 to 26.4V DC)									
Rated current consumption		Max. 400mA									
Weight (including cable)		Sensor section: Approx. 220g			Controller section: Approx. 255g						

* The value when a target is measured in the range of ±7mm for ANL1451 REC, ±17.5mm for ANL1751 REC and ±35mm for ANL1651 REC. The linearity error characteristics outside this range correspond to those of the material error. And when the value is represented by the displacement from the center point (CP), the formula of the linearity error is ±20µm plus ±0.2% x Distance from CP (ANL1451 REC), ±50µm plus ±0.2% x Distance from CP (ANL1751 REC), ±100µm plus ±0.2% x Distance from CP (ANL1651 REC).

** The value is based on standard targets. And when the value is represented by the displacement from the center point (CP), the formula of the material error is ±50µm plus ±0.5% x Distance from CP (ANL1451 REC), ±125µm plus ±0.5% x Distance from CP (ANL1751 REC), ±250µm plus ±0.5% x Distance from CP (ANL1651 REC).

WARNING

- This product utilizes a class 2 laser (wavelength: 670nm) as the light source of the sensor.
For safety reasons, **avoid direct or indirect (e.g. reflection from the glossy target) exposure to beam.**
- **To avoid direct exposure to beam**, it is recommended that the sensor be installed so that the beam height is higher or lower than operators' eyes. Further, the sensor should be fixed so that its beam hits diffuse-reflective or dark targets. **Be sure not to expose your eyes to the beam or the reflected beam from the glossy targets.**
- For safety reasons, **do not disassemble the unit.**
This product may not have an automatic laser-shutoff function when the unit is disassembled. Please contact us if the unit needs repair.
- **CAUTION**
Use of controls or adjustments or performance of procedures other than those specified herein may **result in hazardous radiation exposure.**

(Regarding the Nominal Ocular Hazard Distance)

The power of its laser radiation is beyond the Maximum Permissible Exposure (MPE). However, if the distance from the aperture is longer, the projection beam dimension becomes larger and the laser power per square meter is smaller. The table shown shows the relation between the beam divergence and the distance (NOHD) from the laser aperture.

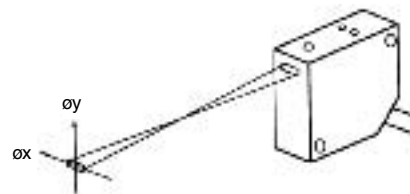

		Beam divergence angle øx x øy (°)	NOHD (m)
LM100	ANL1451REC	1.6 x 1.0	1
	ANL1751REC	0.8 x 0.5	1.9
	ANL1651REC	0.4 x 0.3	3.2
LM200	ANL2335REC	3.1 x 1.6	0.5
	ANL2535REC	2.5 x 1.5	0.6

LM100/LM200

LM 200 Series

		ANL2335REC	ANL2535 REC				
Center point distance		30mm	50mm				
Measurable range		±3mm	±6mm				
Light source		Laser diode, wavelength 670nm (pulse duration 8.3μs, 50% duty ratio)					
Laser protection class		Class 2 (Max. output 1.9mW)					
Output voltage		±3V/F.S. (0 to 6V/F.S. SW selectable) Max. 2mA					
Output impedance		50Ω					
Resolution (2σ)	White ceramic	1.5μm (30Hz)	5μm (300Hz)	15μm (3kHz)	4.5μm (30Hz)	15μm (300Hz)	45μm (3kHz)
	Gray ceramic						
Linearity error *		Max. ±0.2% of F.S.					
Material error **		Max. ±0.5% of F.S.					
Zero-point adjustment range		10% of F.S.					
Temperature drift		Sensor section: Max. ±(0.02% of F.S.)/°C Controller section: Max. ±(0.01% of F.S.)/°C					
Response frequency (-3dB)		3kHz	300Hz	30Hz			
Response time (10 to 90%)		0.15ms	1.5ms	15ms	(SW selectable)		
Alarm output		Transistor output (NPN): 100mA, 30V DC (Open collector)					
Intensity output		0 to 4.5V					
Protective construction (sensor)		IP67					
Vibration resistance (when mounted with screws)		10 to 55Hz (1 cycle/min.), double amplitude	0.75mm (controller section) 1.5mm (sensor section)		2h on 3 axes		
Shock resistance (when mounted with screws)		Min. 20G, 3 times on 3 axes					
Ambient light level		Incandescent lamp: Max. 3,000 lux					
Ambient temperature		0°C to 50°C					
Storage temperature		-20°C to 70°C					
Ambient humidity		35% to 85%RH (without dew condensation)					
Rated operating voltage		100/110 to 120V AC, 200/220 to 240V AC (-15 to +10%)					
Rated power consumption		Max. 15VA					
Weight (including cable)		Sensor section: Approx. 320g		Controller section: Approx. 830g			

Notes

- Unless otherwise specified, the measurement conditions are the rated operation voltage, 20°C ambient temperature, G in LOW, response 10Hz (LM100), 30Hz (LM200) and white ceramic as a target.
- Center point distance:
The distance from the front of laser emitting face to the center of measurable range
F.S.: measurable range (ex. ANL 1451 REC: 20mm)
Resolution:
The standard deviation σ in the variation of the values measured at the center point distance should be doubled, and the result is converted into the distance.

Standard targets

	Diffuse reflection factor	Glossiness
White ceramic	95%	3%
Gray ceramic	17%	2%
Rolled steel plate	29%	69%
Copper	43%	15%
Aluminium	56%	37%
Black rubber	5%	8%

- * The value when a target is measured in the range of ± 2mm for ANL2335REC and ± 4mm for ANL2535REC. The linearity error characteristics outside this range correspond to those of the material error. And when the value is represented by the displacement from the center point (CP), the formula of the linearity error is ± 6μm plus ± 0.2% x Distance from CP (ANL2335REC), ± 12μm plus ± 0.2% x Distance from CP (ANL2535REC).
- ** The value is based on standard targets. And when the value is represented by the displacement from the center point (CP), the formula of the material error is ± 15μm plus ± 0.5% x Distance from CP (ANL2335REC), ± 30μm plus ± 0.5% x Distance from CP (ANL2535REC).

SAFETY (Conforming to CENELEC HD 482 S1 requirements)

● Key switch

Laser radiation is emitted only when the switch is turned on.
The key is removable in the OFF position.

● Remote interlock terminals

Laser radiation is emitted only when these terminals of the controller section are connected.

● Laser emission indicator LED

Comes on when laser radiation is emitted.

● Delayed laser emission

Laser radiation is activated approx. 5s after the laser radiation emission indicator comes on.

● Beam stopper

A beam stopper is attached to this product. To prevent accidental human exposure to laser radiation, set the beam stopper over the laser emitting faces when laser operation is not required.

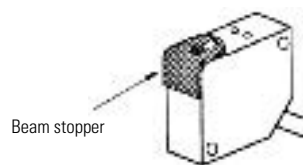

Time chart

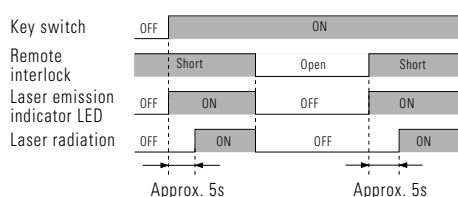

● Labels

The warning labels and the aperture labels are attached to the sensor section.
Explanatory labels are included in the package.
It should be affixed near the unit.



LM100/LM200

PARTS TERMINOLOGY AND FUNCTIONS

1. Parts terminology

● LM100

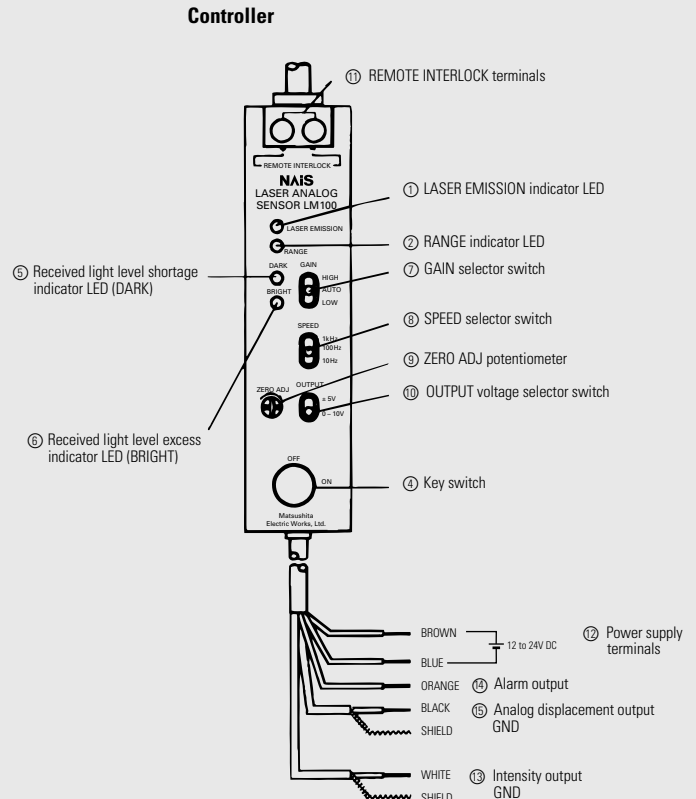
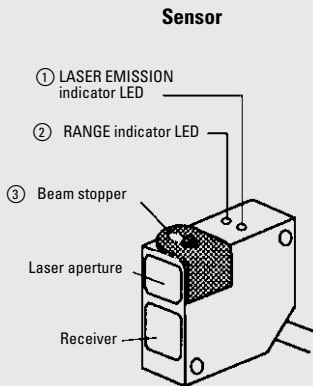

2. Functions

① LASER EMISSION indicator LED

It is lit while or just before the laser radiation is emitted.

② RANGE indicator LED

It shows the detection condition as below.

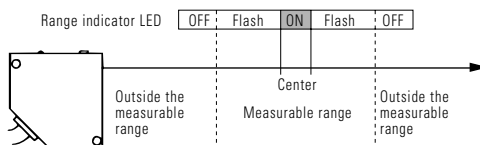

③ Beam stopper

To prevent accidental human exposure to laser radiation, set the beam stopper over the laser emitting faces when laser operation is not required.

④ Key switch

Laser radiation is emitted only when the switch is turned on.
The key is removable in the OFF position.

⑤ Received light level shortage indicator LED (DARK)

When there is no detectable object or the light level received from an object becomes less than the specified value, it comes ON.

⑥ Received light level excess indicator LED (BRIGHT)

When the light level received from an object exceeds the specified value, it comes ON.

⑦ GAIN selector switch

Usually turned to the LOW side. If the target is within the measurable range and the luminous volume shortage indicator LED (DARK) comes on, it should be switched to the HIGH side.

When the switch is on the AUTO side, either the LOW or HIGH condition is automatically selected.

⑧ SPEED selector switch

It can be selected the response speed according to the speed of the object.

If the high speed response time is not required on your application, select the lowest response position to get the most reliable value.

LM100 series: 1kHz/100Hz/10Hz
LM200 series: 3kHz/300Hz/30Hz

⑨ ZERO ADJ (zero-point adjustment) potentiometer

This potentiometer adjusts the zero-point in the

range of 10% of F.S. This function is useful for the adjustment after the sensor installation.

⑩ OUTPUT voltage selector switch

This switch selects the output voltage range.

LM100: $\pm 5V/0$ to $10V$

LM200: $\pm 3V/0$ to $6V$

Even if the 0 to $10V$ (LM100) or 0 to $6V$ (LM200) mode is selected, the minus voltage is output.

⑪ Remote interlock terminal

Laser radiation can only be activated by connecting these terminals. To prevent human exposure to laser radiation, connect a remote barrier interlock, emergency stop switch, etc. to these terminals.

Note: If a transistor is used to close this input, ON-state voltage must be 1.5V or less. Be certain to use fail-safe electromechanical devices as interlocks where required.

⑫ Power supply terminals

LM100 Series: 12 to 24V DC

LM200 Series: 200/220 to 240V AC
unit available.

LM100/LM200

● LM200

Controller

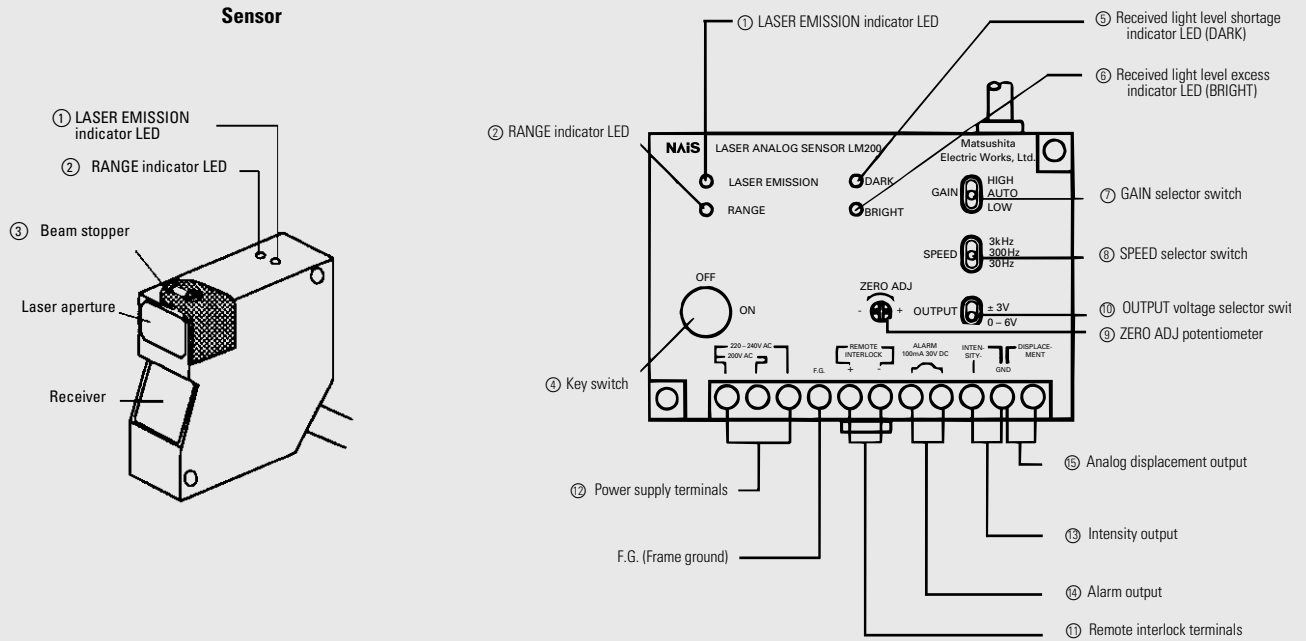

⑬ Intensity output

The light intensity is output as a voltage signal. The output voltage rises up to 4.5V as the light intensity increases and goes down to 0V as the light intensity decreases.

If the output voltage drops below 3V, the detection may be unstable because of the shortage of laser light.

<Output circuit diagram>

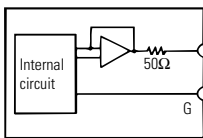

⑭ Alarm output

This output is energized when the luminous volume received from an object exceeds or becomes less than the specified value. (100mA 30V DC open collector)

The specified response time is required to get the correct value after the alarm output is cancelled.

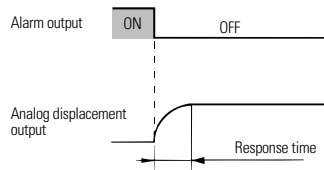

<Output circuit diagram>

LM100

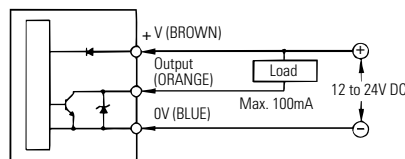

LM200

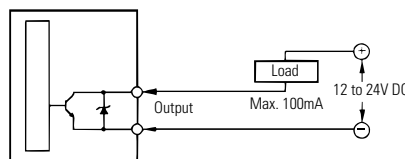

⑮ Analog displacement output

Distance variation is output as a voltage signal.

LM100 Series: $\pm 5V$ or 0 to 10V

LM200 Series: $\pm 3V$ or 0 to 6V

When the measurement is not possible because of the luminous volume shortage (DARK) or excess (BRIGHT), the value measured just before the error is held.

With using this function, stable measurement can be obtained even if the luminous volume shortage or excess is occurred in a short time.

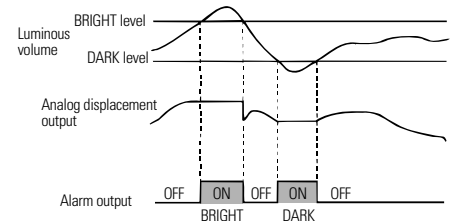

LM100/LM200

mm

DIMENSIONS

● LM100 Series

Sensor

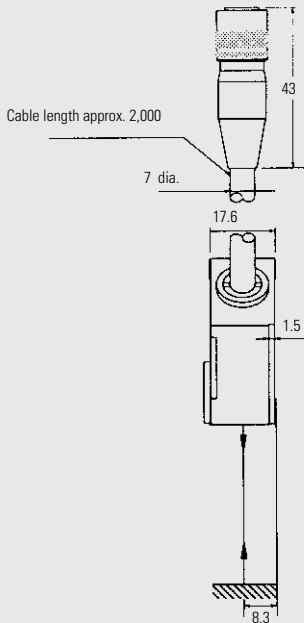

	h_1	h_2	θ
ANL1451EC	40	40.3	20°
ANL1751EC	75	75.3	14°
ANL1651EC	130	130.3	9°

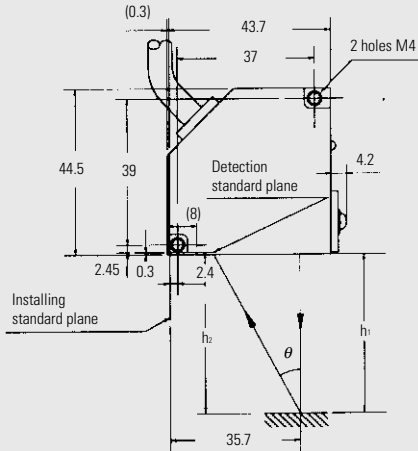

Controller

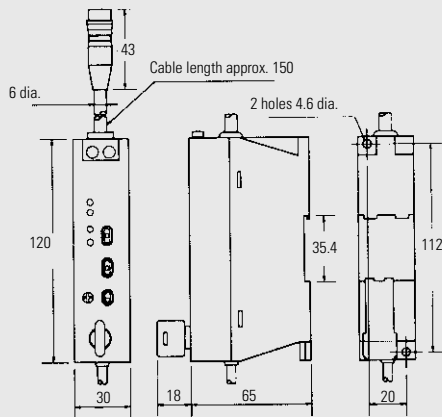

● LM200 Series

Sensor

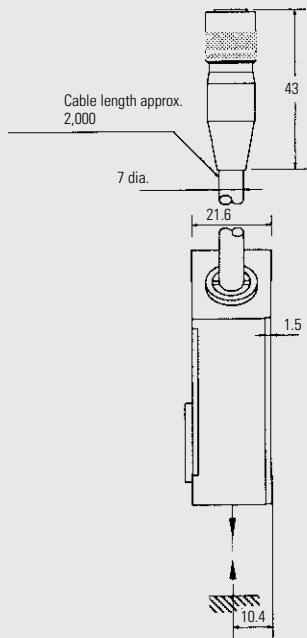

	h_1	h_2	θ
ANL2334EC, ANL2335EC	30	25.5	36°
ANL2534EC, ANL2535EC	50	45.5	30°

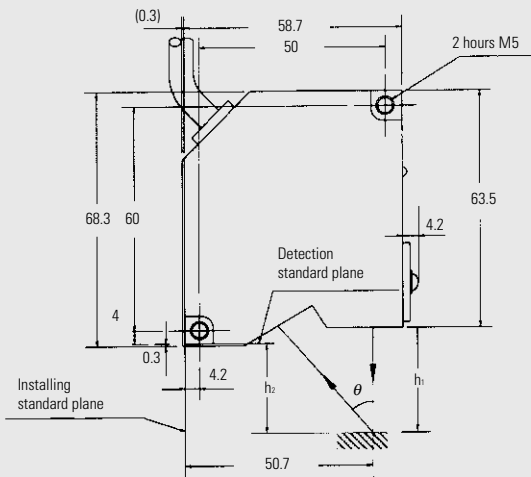

Controller

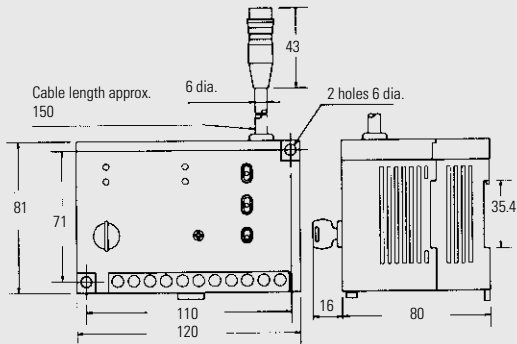

General tolerance ± 1.0

Projection beam dimensions

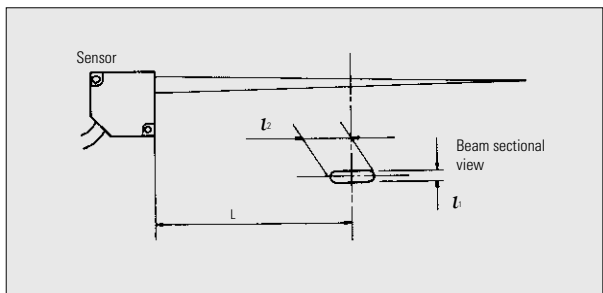

LM100 Series

ANL1451REC			ANL1751REC			ANL1651REC		
L (mm)	l_1 (mm)	l_2 (mm)	L (mm)	l_1 (mm)	l_2 (mm)	L (mm)	l_1 (mm)	l_2 (mm)
30	1.0	2.6	50	1.1	2.9	80	1.1	3.1
40	0.8	2.2	75	0.9	2.5	130	0.9	2.6
50	0.7	1.9	100	0.7	2.1	180	0.6	2.1

LM200 Series

ANL2335REC			ANL2535REC		
L (mm)	l_1 (mm)	l_2 (mm)	L (mm)	l_1 (mm)	l_2 (mm)
27	0.29	0.6	44	0.29	0.6
30	0.25	0.55	50	0.25	0.5
330	0.21	0.45	56	0.22	0.4

LM100/LM200

CAUTIONS

1. Sensor/Controller Pairing

Since the controller and sensor head have been calibrated as a set, be sure they have the same serial number.

2. Operating environment

- Operate the system at ambient temperatures of 0°C to +50°C. Keep the storage temperature within a range of -20°C to +70°C.
- Operate the system at ambient humidity of 35% to 85% RH.
- Keep ambient incandescent light at 3,000 lux or below.
- Use a power supply voltage within a range of 85% to 110% of the rated voltage.
- Keep the light projection and receiving faces of the sensor clean. Prevent adhesion of water, oil and fingerprint which may refract light or dust and dirt which may block light.
Use a soft cloth or cleaning paper when to wipe the surface of the sensor.
- Prevent excessive light from directly entering the light receiver of the sensor. Particularly when high accuracies are required, attach a shade.
- Avoid use in areas where inflammable or corrosive gases are generated; it is very dirty; water or oil is directly splashed, or shock and vibration are considerable.
- The sensor section is of immersion protected type, but this does not mean that it can be used in water or where there is direct impingement of rain for detecting objects.
- Since the controller main body uses molding resin, prevent adhesion of organic solvents such as benzene, thinner and alcohol or strong alkali materials such as ammonia and caustic soda, and use of the unit in atmospheres of the above.
- If the external surge voltage exceeds 500V (LM100 Series), 4,000V (LM200 Series) {±(1.2 x 50)µs unipolar full wave voltage}, the internal circuit may be damaged. Therefore, a surge absorbing element shall be used.

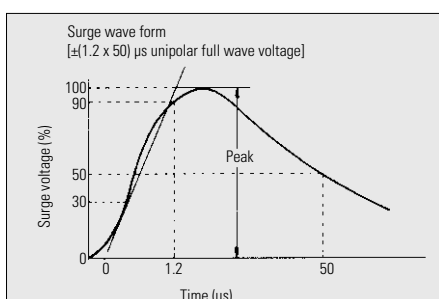

3. Noise

- Keep the system as far as possible from the high voltage cables, high voltage equipment, power cables, power equipment, wireless equipment, transmitter integrated equipment, large surge generating equipment and so on.
- When routing the sensor cable and the analog output wires, separate them from the wires of the power circuits and high voltage circuits.
- Metallic portions of the sensor head and connector are connected with the GND of the analog output. For the prevention of noise influence and noise-caused damage on internal circuits, don't allow any voltage difference between the sensor and the GND of analog output.
- Analog output resolution may be influenced by noise in the circumstances. If the expected output value cannot be obtained, put a noise filter (C-R circuit: see below) between the voltage output terminals (wires) and the load to avoid a sensor noise loop. The noise filter should be placed as near to the load as possible to eliminate the influence of the noise.

The recommended values of a C-R circuit are:
Resistance: 51Ω (allowable power dissipation: Min. 1/2W)
Capacitor: 0.1µF (withstand voltage: Min 50V DC)

This filter will not influence the response speed of the sensor. If the value of resistance in the C-R circuit is increased, the influence of noise is well eliminated, however, there may cause deviations in output linearity.

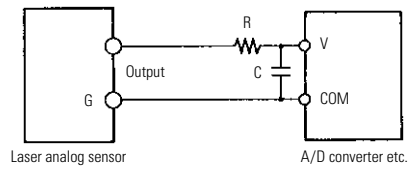

4. Insulation resistance, withstand voltage

Insulation resistance (between live and dead metal parts)

LM100: Min 20MΩ
LM200: Min 100MΩ

Withstand voltage (between live and dead metal parts)

LM100: 500V AC for 1 min
LM200: 4000V AC for 1 min

To prevent damage on internal circuits, these tests between the sensor and live part/the metallic portions of the connectors and live part/the key switch (controller) and live part are prohibited.

5. Power supply (for LM100 series)

When a commercially available switching regulator is used as a power supply, be sure to ground the frame ground terminal of the switching regulator to avoid influence from the high frequency noise. When a transformer is used as a power supply, use a transformer with the primary and the secondary sides isolated in order to prevent interference of the power supply circuit.

6. Warming-up time

For the use in which high precision is required, be sure to secure the warming-up time of 30 min or more after power is turned ON.

INSTALLATION

1. Sensor setting

- Fix the sensor so that the target is placed in the measurable range using the range indicator LED.

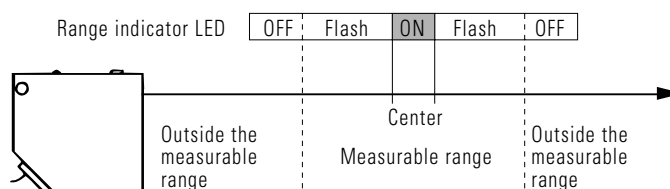

- Movement direction of the target
In the examples as shown below, an error may result depending on the installation direction of the sensor. To minimize the error, select the optimum installation direction.

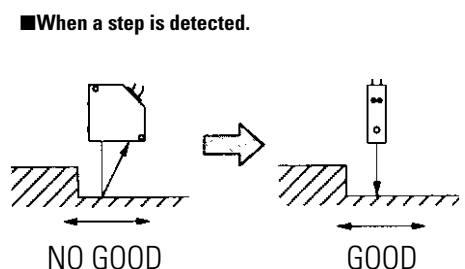

LM100/LM200

■ When an eccentricity of round parts is detected.

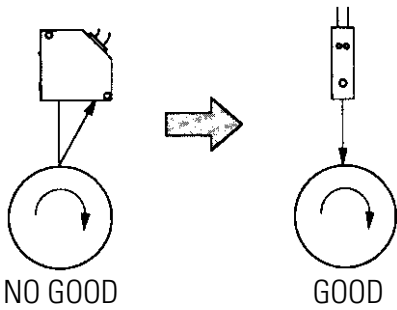

■ When a boundary line exists.

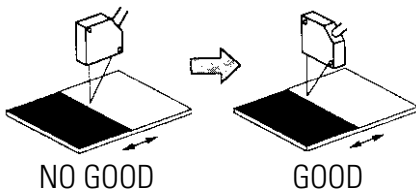

- Confirm the mutual interference area as below when using sensor heads side by side.

		a	b	c
LM100	ANL1451REC	30	20	60
	ANL1751REC	70	20	80
	ANL1651REC	100	70	120
LM200	ANL2335REC	30	10	10
	ANL2535REC	30	10	10

2. Sensor installation

When installing the sensor, be sure to make its installing standard plane and detection direction in parallel with each other, and also to make detection standard plane and a target in parallel with each other. The sensor must be fixed securely with the two M4 (LM100), M5 (LM200) screws.

■ How to use the beam stopper

- ① Loosen the fastening screw (no need to remove the screw)
- ② Slide the beam stopper to the direction as shown at the left. Then rotate the beam stopper to the front of the sensor.
- ③ Fix the beam stopper and securely fasten the screw.

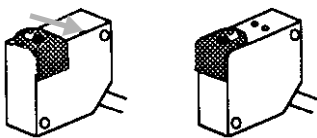

3. Controller installation

To mount the controller on DIN rail, pull the hook to release the lock. Push the hook back in when the unit is positioned on the rail and it will be locked in place. The controller can also be mounted with screws.

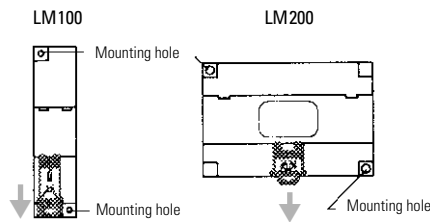

4. Wiring

- Be sure to connect correctly referring to the explanation of the input and output circuit and the instructions mentioned on the case.
- When crimp terminals are used, the pre-wired terminals should be fastened with UP terminal (M3.5 screws).

(Suitable crimp terminal)

- ① Bare round terminal
- ② Bare round terminal with insulated paper
- ③ Open-end terminal

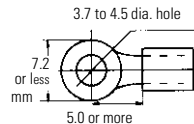

5. Connector

- Before connection or disconnection, be sure the power is off.
- Do not touch exposed plug prongs.

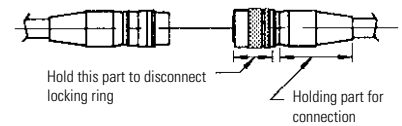

6. Cable

- Do not subject sensor cables to more than 3kg of force during mounting.
- When the sensor is placed on a movable installation, fix both ends of the sensor cable to keep the cable from being subjected to excessive force.
- Only bend the sensor-side's end of the cable as shown at the right.

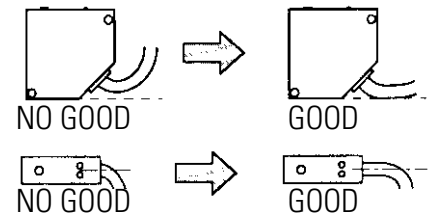

LM100/LM200

■ When an eccentricity of round parts is detected.

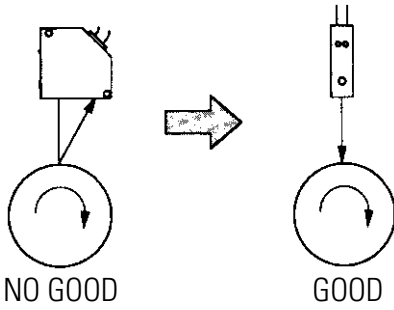

■ When a boundary line exists.

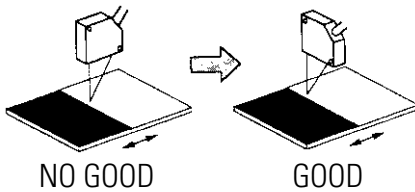

- Confirm the mutual interference area as below when using sensor heads side by side.

		mm		
		a	b	c
LM100	ANL1451REC	30	20	60
	ANL1751REC	70	20	80
	ANL1651REC	100	70	120
LM200	ANL2335REC	30	10	10
	ANL2535REC	30	10	10

2. Sensor installation

When installing the sensor, be sure to make its installing standard plane and detection direction in parallel with each other, and also to make detection standard plane and a target in parallel with each other. The sensor must be fixed securely with the two M4 (LM100), M5 (LM200) screws.

■ How to use the beam stopper

- ① Loosen the fastening screw (no need to remove the screw)
- ② Slide the beam stopper to the direction as shown at the left. Then rotate the beam stopper to the front of the sensor.
- ③ Fix the beam stopper and securely fasten the screw.

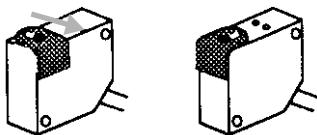

3. Controller installation

To mount the controller on DIN rail, pull the hook to release the lock. Push the hook back in when the unit is positioned on the rail and it will be locked in place. The controller can also be mounted with screws.

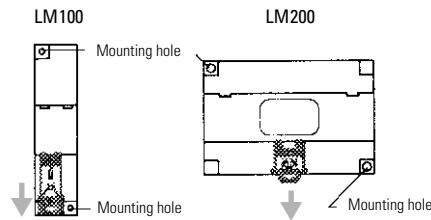

4. Wiring

- Be sure to connect correctly referring to the explanation of the input and output circuit and the instructions mentioned on the case.
- When crimp terminals are used, the pre-wired terminals should be fastened with UP terminal (M3.5 screws).

(Suitable crimp terminal)

- ① Bare round terminal
- ② Bare round terminal with insulated paper
- ③ Open-end terminal

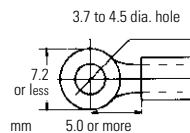

5. Connector

- Before connection or disconnection, be sure the power is off.
- Do not touch exposed plug prongs.

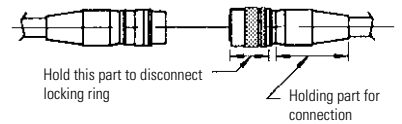

6. Cable

- Do not subject sensor cables to more than 3kg of force during mounting.
- When the sensor is placed on a movable installation, fix both ends of the sensor cable to keep the cable from being subjected to excessive force.
- Only bend the sensor-side's end of the cable as shown at the right.

